

Basalt-fibre-reinforced polymer reinforcement

Su Taylor, D Robinson and M Sonebi of the School of Planning, Architecture and Civil Engineering (SPACE), Queen's University Belfast describe a project to replace corrodible steel reinforcement with highly durable basalt-fibre-reinforced polymer (BFRP) reinforcing bars and monitoring their performance in comparison with steel using discrete optical sensors embedded in the concrete.



Figure 1: Thompson's Bridge.

Thompson's Bridge (see Figure 1), in Northern Ireland, is a beam-and-slab design and typical of the vast majority of medium-span concrete bridges in Europe and the rest of the world. Many modern bridges and marine structures using steel-reinforced concrete have required extensive repair after being in service for a

relatively short period of their design life. Much of this is due to corrosion of the steel reinforcement embedded in the concrete and as a consequence, many of these bridges are unable to meet current loading standards without costly strengthening work.

The Department for Regional Development Roads Service (DRD NI) has sole responsibility for the management of all public road bridges in Northern Ireland. The total number of bridges on motorways, trunk and non-trunk roads is approximately

6000 and the annual expenditure on the maintenance and strengthening of minor structures is approximately £5 million.

Durability and sustainability are now recognised as key issues that must be addressed in the design, construction and life-long performance of civil infrastructure. So another aim of this project was to reduce the energy consumption in the materials and in whole-life performance of the bridge. By using the benefits of durable, light and high-strength BFRP bars, in combination with lower-energy self-compacting concrete (SCC) it should be possible to produce economic and durable concrete structures with improved whole-life performance compared to many current bridges.

Sustainability by design

The significance of designing a durable concrete deck system cannot be overemphasised as in the last 20 years many concrete bridges have exhibited problems associated with reinforcement corrosion and their repair can cause disruption to traffic and the associated costs of congestion are high.

A further problem for bridge deck slabs is the need to carry heavier lorries under new increased European loadings. However, the inherent strength due to compressive membrane action (CMA), is not taken into account in normal flexural design approaches; such as in the current structural Eurocode design Standard⁽¹⁾. This enhancement has been recognised by a number of bridge authorities (CHBDC, 2005 and NI, 1995) and Highways Agency guidance, BD 81/02⁽²⁾,

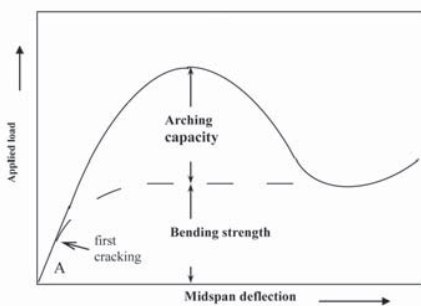
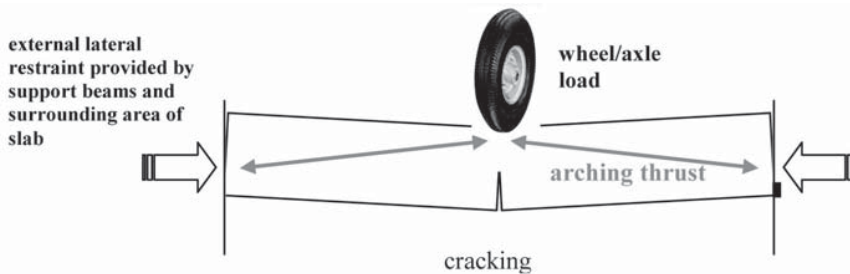

Figure 2 top: Arching action in a typical concrete bridge deck slab.

Figure 3 above: Interaction between flexural and arching action.

Figure 4 right: BFRP-reinforced bridge deck slab.



BFRP reinforcement bar in the bridge deck slab over W-beams



Figure 5: Positioning of BFRP bar with fibre bragg grating sensors.

which came about as a direct result of research at Queen's University Belfast (see Figures 2 and 3). BD 81 is now being used by some consultants for the design of new bridges and can offer substantial economies in the percentage of reinforcement in comparison to Eurocode 2. CMA design that takes into account the beneficial effects of arching action can ensure lower percentages and the use of alternative non-corrodible forms of reinforcement to provide a more durable bridge deck slab.

Fibre-reinforced polymer (FRP) reinforcement is a good alternative as it is non-corrosive, lightweight and in the case of BFRP has about 50% higher tensile strength than high-yield steel. However, the brittle behaviour and low modulus of elasticity have been perceived to be potential drawbacks to the use of FRP.

Recommendations for design are provided by some design codes such as ACI 440⁽³⁾ but these do not take into account the beneficial effect of CMA on both the service behaviour and the ultimate strength.

Optical sensors

Another strand of this project was to make use of discrete optical sensors for monitoring the embedded BFRP bars under load testing. The Engineering and Physical Sciences Research Council (EPSRC) is funding the authors to further develop optical sensors for monitoring the corrosion of steel in concrete structures in a marine environment and this collaboration between electrical and civil engineers has enabled embedded

structural health monitoring with little or no interference to the behaviour of the structure. Fibre bragg gratings on the optical cable use lightwaves to detect change in strain and therefore multiple sensors can be used on one cable unlike other strain sensors, which require bulky packaging and individual cabling. Figures 4 and 5 show the position of the bars with sensors in the bottom layer of reinforcement.

Bridge description

Thompson's Bridge was a replacement bridge to carry the A509 in County Fermanagh. It consists of a fully integral single-span skew bridge. The mid-span section was constructed with basalt-fibre-reinforced polymer (BFRP) bars of 12mm diameter and the remaining slab had 12mm steel reinforcement. The details of the deck slab are given in Table 1.

Test details

The test areas are shown in Figure 6. One of the main criteria for this test programme was to assess the influence of the reinforcement type on the service behaviour of the bridge deck slab. The central region of the bridge deck slab had BFRP reinforcement of 0.6% and the remaining slab had 0.7% steel reinforcement. Concrete cube samples were taken for each batch to ascertain the strength at the time of testing.

A simulated wheel load was applied to each test panel using a self-straining test rig. A typical test arrangement is depicted in Figure 7. A circular concentrated load was applied at the mid-span of each test panel via a 300mm-diameter plate. Fibre bragg gratings measured strain in the reinforcement bars and electronic displacement transducers were positioned along the centre line of the panel to enable a profile of the deflected shape.

Test results

Results for the maximum vertical deflections are given in Figure 8. The deflections were similar in all of the test area and all below 2mm at a maximum load of 40 tonnes. However, the test regions with steel reinforcement had slightly higher deflections, particularly test region 6 compared with test regions 2 and 3 where the deflection in the steel-reinforced section was twice that of the equivalent BFRP-reinforced region. However, the magnitude of the deflections was low in all the test panels up to the maximum applied test load.

In the 1.6m spanning slabs, the deflection at an applied load of 300kN (or twice the European wheel load) varied between 0.33 and 1.14mm, which was equivalent to a maximum of span/1404 in the slab. In the

Table 1 – Thompson's Bridge deck slab data

Overall bridge length	32m
Effective deck slab span	1.4m between W-beams 1.6m over W-beam
Depth of deck	0.2m
Width of bridge	8m
Reinforcement	0.6% BFRP in central region
Concrete compressive strength	50.5MPa

Table 2 – BFRP material properties

Reinforcement	Tensile Tests loading rate 0.2kN/s			Manufacturer's reported values loading rate 1kN/s		
	Tensile strength (MPa)	Elastic modulus (GPa)	Ultimate strain $\mu\epsilon$	Tensile strength (MPa)	Elastic modulus (GPa)	Ultimate strain $\mu\epsilon$
12mm BFRP	920.0	54.0	17,037.0	1200.0	50.0	24,000.0

Table 3 – Predicted capacity using CMA theory from BD 81

Concrete compressive strength* (MPa)	f'_c / γ_m	Reinforcing bar (% BFRP)	d (mm)	Slab clear span (m)	h (mm)	L/h	k	ρ	$P_{BD 81}$
50.5	26.67	0.5	148	1.226	200	6.13	0.1934	0.039	569kN

REINFORCEMENT

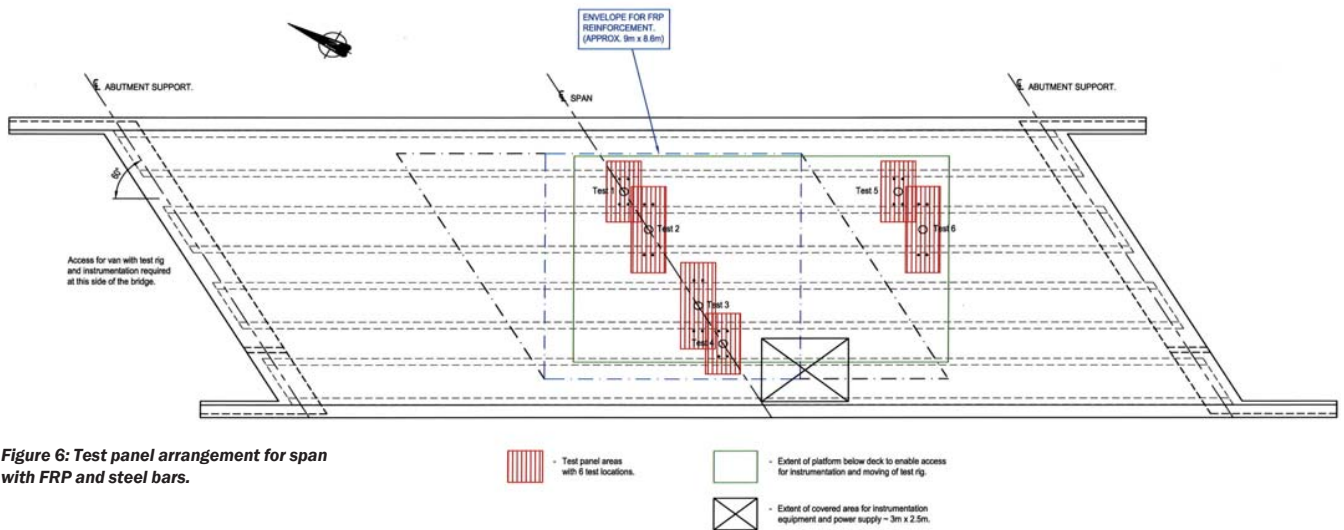

Figure 6: Test panel arrangement for span with FRP and steel bars.

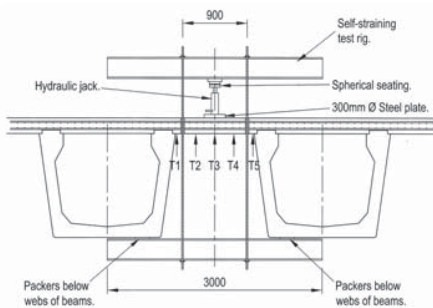

Figure 7: Bridge deck cross-section and typical test arrangement for slab between W beam.

1.4m spanning slabs, the deflection at an applied load of 300kN varied between 0.3 and 0.48mm which was equivalent to a maximum of span/2917 in the slab with steel reinforcement. This indicates extremely low deflections and well within current acceptable limits for reinforced concrete elements and is due to the beneficial influence of compressive membrane action on service behaviour. The areas of slab with BFRP reinforcement showed lower deflections than the equivalent steel reinforced areas of slab.

The results for the strain in the BFRP reinforcement are given in Figure 9. The maximum value of strain recorded was 1993 $\mu\epsilon$ in test region 4. Table 2 shows the material properties of the BFRP bars based on the average of tests on control samples. The measured ultimate strain of the bars was 17037 $\mu\epsilon$ so the maximum value of strain at an applied wheel load of 40 tonnes was 11.7% of the maximum possible strain in the bar

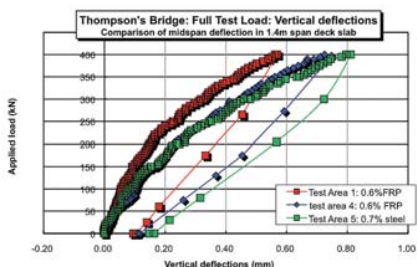

Figure 8: Comparison of mid-span vertical deflections in spans between W beams (1.4m span).

and represents a factor of safety of 8.5. This aligns with the very low value of deflections measured in these test areas and suggests that the applied load of 40 tonnes was well within the service loading of the bridge deck slab. The strain measured by the sensors also showed good recovery after unloading, verifying that the slab was in the service load region.

Compressive membrane theory from BD 81

Beam-and-slab bridge decks are one of the most common forms of bridge construction in Europe and the rest of the world. Since these slabs are restrained against lateral expansion by the supporting beams, the application of vertical loading, such as a wheel load, results in compressive membrane action/arching action (CMA) as shown in Figure 2.

BD 81/02 outlines a means of assessing the true capacity of a deck slab by incorporating arching theory; Table 3 shows the predicted capacities. It can be seen that, by taking into account arching action, substantially higher capacity is achieved than the capacities predicted using current flexural theory or elastic analysis. Further work is to be carried out to compare predicted stresses using Non-Linear Finite Element Analysis (NLFEA) with those measured during the load test.

Concluding remarks

It can be concluded that the BFRP-reinforced concrete bridge deck slab in Thompson's Bridge exhibited lower deflections than the similar steel-reinforced bridge deck slab. The

deck slab was capable of supporting a wheel load of 40 tonnes with no detrimental effect and with strain values well within the service load range. There was no visible cracking on top of the slab and hairline cracking in the soffit in the 1.4m slabs.

All of the test regions showed excellent recovery in deflection and strain after unloading. The maximum test load was nearly three times the current maximum European wheel load. The maximum deflection in the BFRP slab was 0.78mm at an applied load of 40 tonnes and is equivalent to a ratio of effective span/2054, which is well within acceptable limits for deflection. The maximum deflection occurred at mid-span. The strain values were very low and 8.5 times less than the rupture strain of the BFRP bars at an applied load of 40 tonnes, which is far in excess of the current EU wheel load of 15 tonnes.

The BFRP reinforcement bar provides an alternative corrosion-resistant system, which has substantially improved whole-life performance compared with corrosive steel reinforcement bar. ●

Acknowledgements:

Thanks to funding bodies and industrial partners who have supported this project: Department of Transport; DRD (NI); Sengenja Ltd; Ltd, Aecom, Amey Plc, McLaughlin and Harvey, UK Bridge Owners Forum, Banagher Concrete, City University London and QUB staff: K McDonald, D Ferguson, B Rankin, D Cleland and G Tharmarajah.

References

- BRITISH STANDARDS INSTITUTION, BS EN 1992-1-1. Eurocode 2: Design of concrete structures. General rules and rules for buildings. BSI, London, 2004.
- HIGHWAYS AGENCY, BD 81/02. Use of compressive membrane action in bridge decks. Design Manual for Roads and Bridges, Volume 3, Section 4, Part 20, August 2002.
- AMERICAN CONCRETE INSTITUTE, ACI 440 1R-03. Guide for the Design and Construction of Concrete Reinforced with FRP Bars. ACI, Michigan 2003.

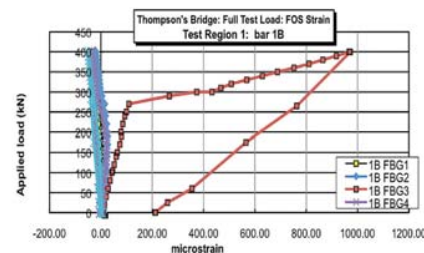

Figure 9: Micro-strain values in bar 1B - test region 1 with BFRP reinforcement bar.